

HV280ML

Single Door 280kg Magnetic Lock



HV280ML Single door electromagnetic locks are built in LED and has holding force of 280Kg. It has zinc finishes for magnetic and armature; and the shell is of anodized surface texture processing.

Application

Office areas, schools, communities, office buildings, hotels, shopping malls, shops, public service places, etc.

SPECIFICATION

Input Voltage	DC12V
Working Current	450mA±5%
Tensile Force Range	200Kg±5%
Weight	1.77Kg
Lock Body Size	250x47x25.5 mm
Iron Plate Size	180x38x11 mm
Interface Description	V + - Positive Power Supply ; V - - Negative Power Supply;

FIXING DIAGRAM

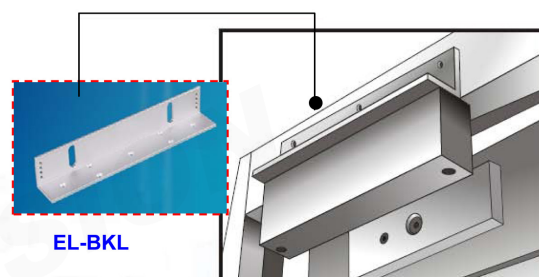

DIMENSIONS

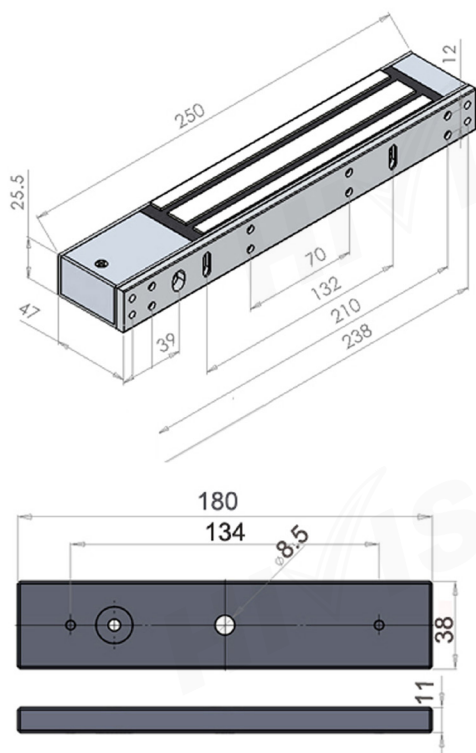

WIRING GUIDE

